

Centrifugal pump P16/ P80 *Kreiselpumpe P16/ P80*

- Regular priming, for liquids to 80°C, hydraulic in cast iron, impeller brass, shaft stainless steel, mech seal graph/ ceram
- *Normalsaugend, für klare Flüssigkeiten bis 80°C, Gehäuse GG, Laufrad Messing, Welle Edelstahl, Gltrd Kohle/Keramik*

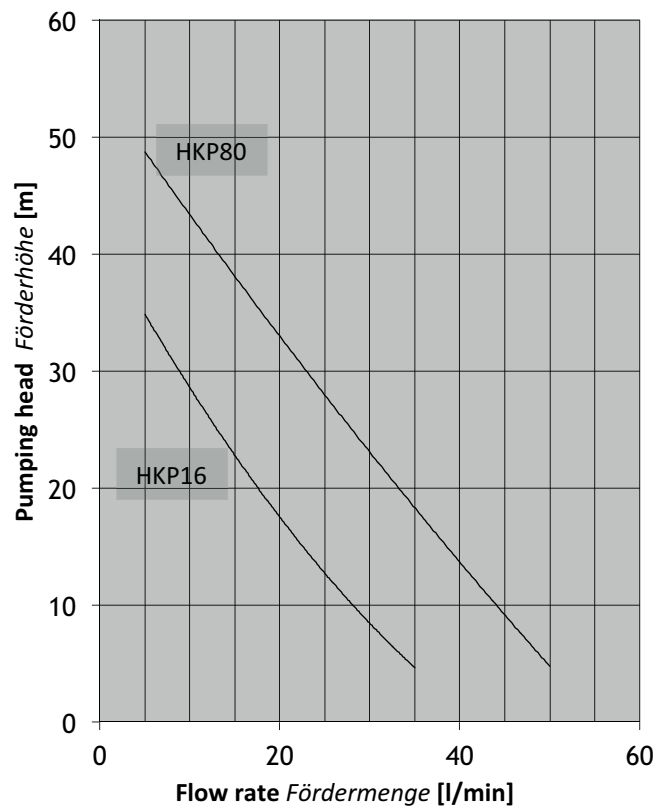
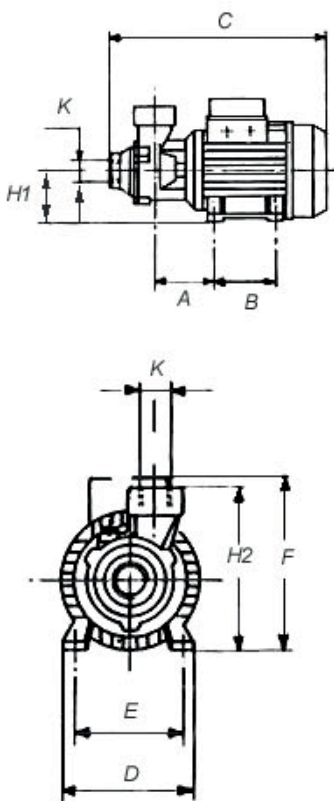

Type	A	B	C	D	E	F	H1	H2	I	Weight [Kg]
HKP16	65	80	260	120	100	156	63	140	1"	6 Kg
HKP80	75	80	292	135	112	172	68	157	1"	9 Kg

Type	Electric Data			
HKP16	0,37 kW	230/400 V	1,8/1,1 A	50 Hz
HKP80	0,6 kW	230/400 V	2,6/1,5 A	50 Hz